

Aritco HomeLift

Aritco HomeLift comes with luxury design features like the DesignWall, a backlit wall with selected art from prominent Scandinavian designers or you can select your own personal picture. It also includes Design-Light, with state-of-the-art lighting that you can control via the SmartLift app. Select between white cool and white warm light and colored light. The ceiling has two light pattern to select from, Stars and Sphere. The lift is equipped with our SmartSafety system, with safety features that anticipate situations and prevent accidents. The covering panels can as option be customized and covered with a plastic film (Design-Panels) that makes them look like either wood (Pine, Oak or Mahogany) or concrete.

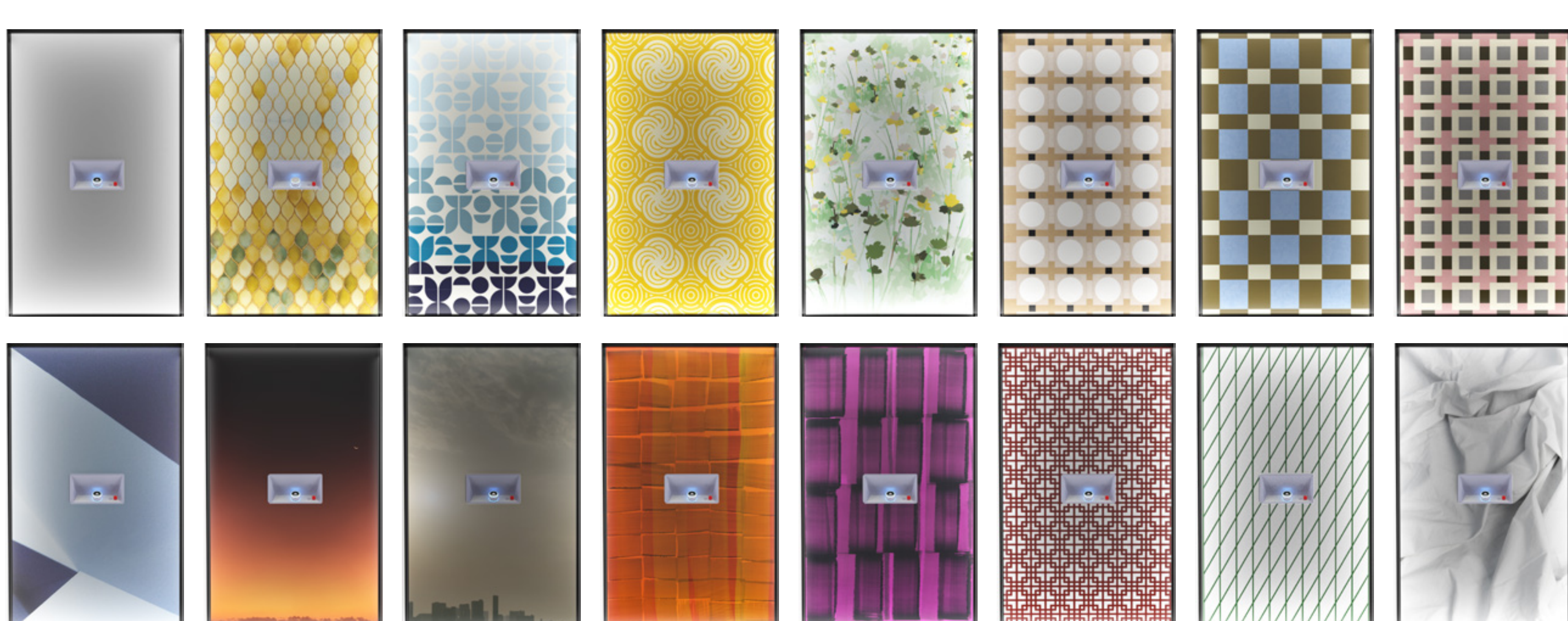

DesignWall



SmartApp

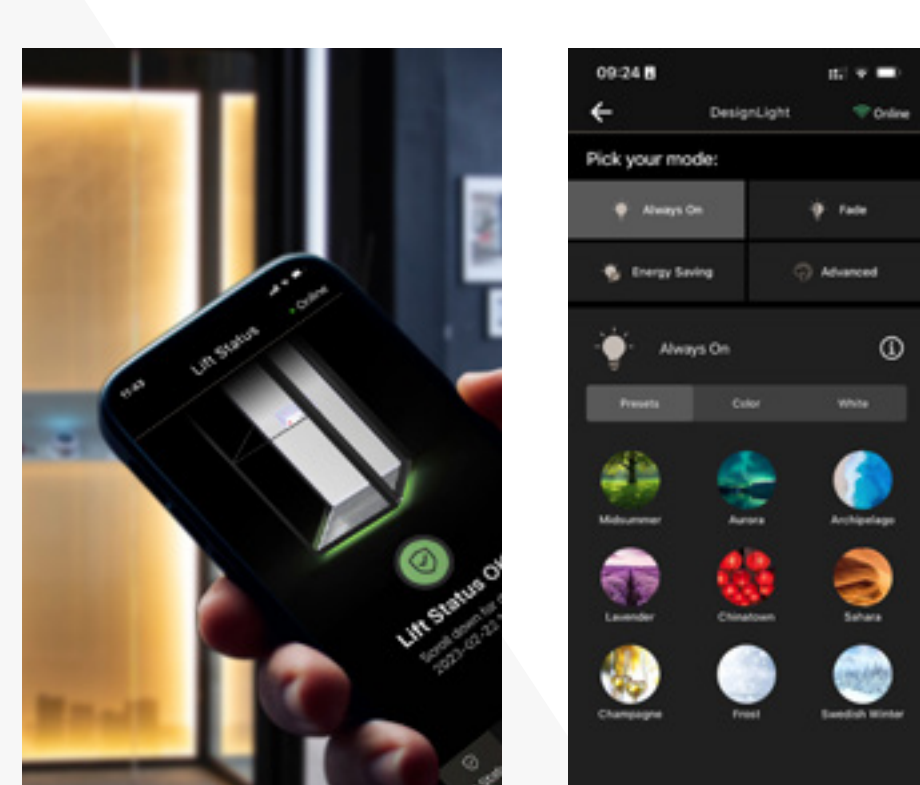

Ceiling

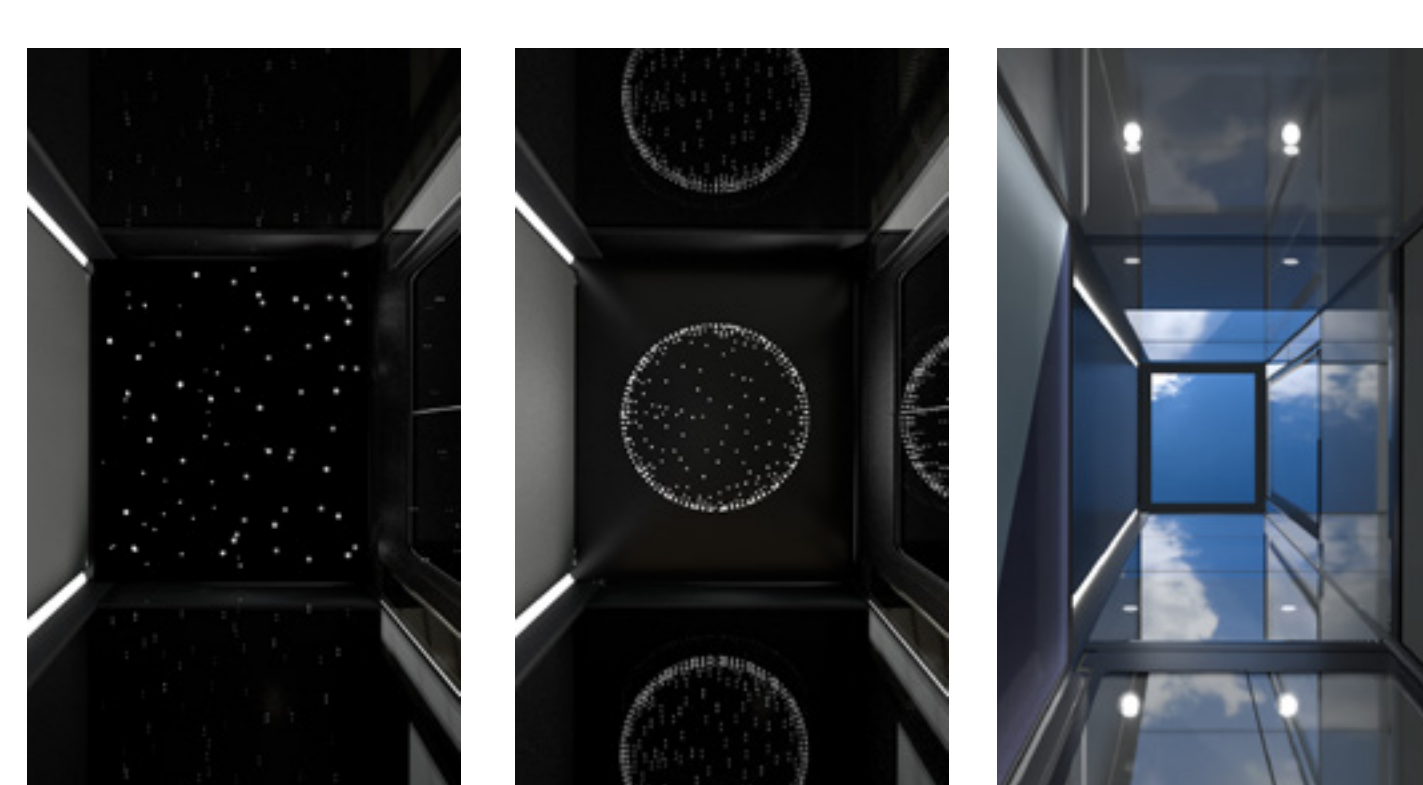

DesignPanels



FLOOR

The floor of the lift adds an extra touch to the design. You have a number of handpicked floors to choose from that matches the colours and the DesignWall of the lift. Your own personal choice is also possible.



GLASS



GLASS PATTERN

Option on standard glass

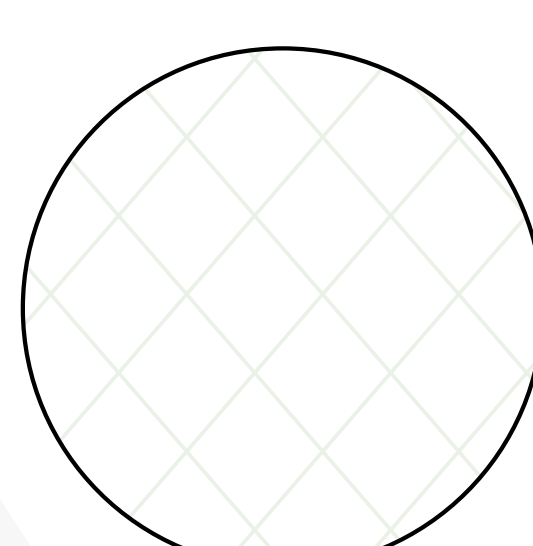

Diamond

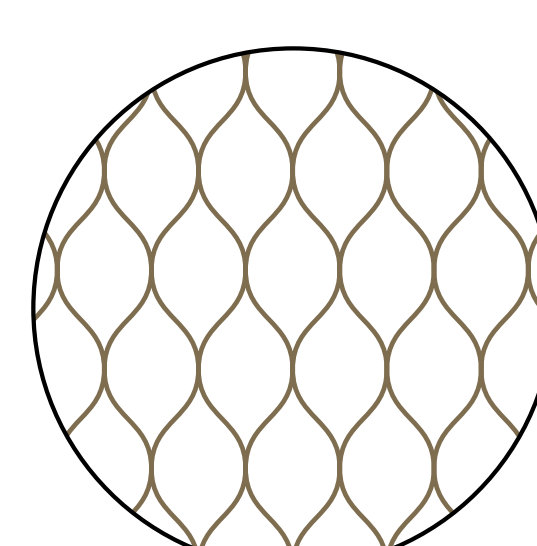

Mesh

LIFT COLOR

By making some of your own choices for your lift, it will fit perfectly into your interior or turn it into a spectacular piece of furniture. We know that every home looks different and understand that you want to design your lift so it matches all parts of your home.



Sizes

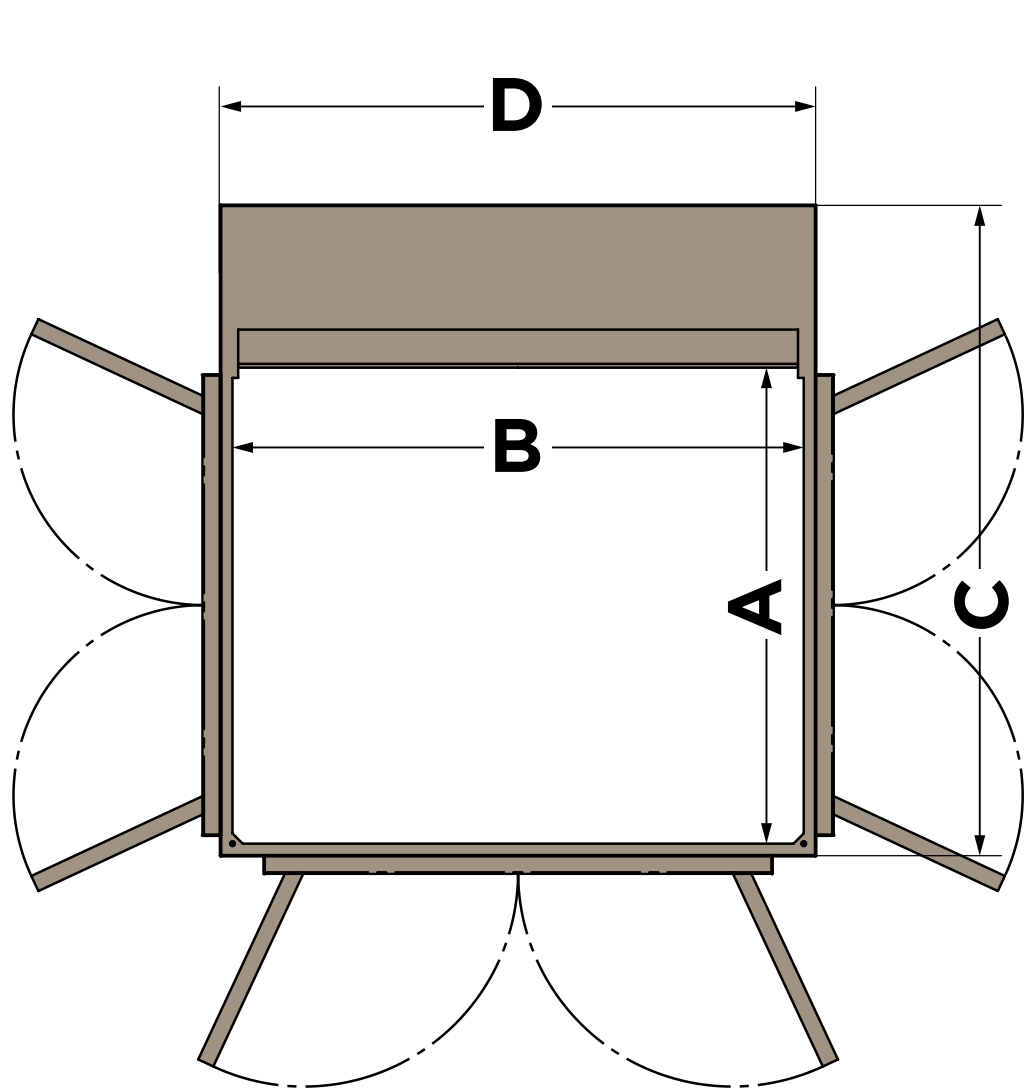

MODEL	CARRIER SIZE (AxB)	EXTERIOR DIMENSIONS (CxD)	RATED LOAD
S5	600 x 830 mm	966 x 880 mm	250 kg / 2 persons
S8	1000 x 830 mm	1366 x 880 mm	250 kg / 3 persons
S9	1100 x 830 mm	1466 x 880 mm	250 kg / 3 persons
S12	1000 x 1200 mm	1366 x 1250 mm	400 kg / 5 persons
S15	1100 x 1400 mm	1466 x 1450 mm	400 kg / 5 persons

Intended use

Installations in private homes
Indoor installation environments

Technical compliance

European Machine Directive 2006/42/EC
European Standard EN 81-41

Drive system

Patented screw-and-nut system

Rated speed

Max 0.15m/s i inside Europe
Max 0.30 m/s outside Europe

Emergency lowering

Battery-powered

Travel height

500-15 000 mm inside Europe
500-18 000 mm outside Europe

Top height

Min. 2 225 mm to
4 000 mm

Number of floors

2 to 6 floors

Installation

Recessed installation 37 mm below floor level
Installed directly on the floor with a ramp

Operation

Hold to run (press and hold)
One-touch operation (press one time) for installations outside Europe

Power supply

230 V 1-phase
400 V 3-phase

Warranty

Aritco HomeLift comes with a 5-year product warranty and a 10-year drive technology warranty.

