

CREATIVE AND INNOVATIVE DESIGN TAILORED TO YOU.

HARMONY FE

Domestic | Interior



innovate
lifts

WHY CHOOSE INNOVATE LIFTS?

Steve Marriner founded Innovate Lifts in 2016 after 40 years of industry experience, to bring new life to the lift industry and push its boundaries.

Compliance with safety standards is a top priority for Innovate Lifts. Our skilled team of experts adds a touch of creativity and uniqueness to every Harmony FE Homelift, ensuring it is tailored to your specific needs. We are committed to providing a personalised and friendly service that exceeds your expectations, and we look forward to bringing innovation and inspiration to your home.

We understand that every customer is different, and we take pride in our ability to listen carefully to your needs and provide compassionate, empathetic solutions that address your concerns effectively. At Innovate Lifts, we are dedicated to supporting you through life's challenges, and we are honored to be a part of your journey.

We will take care of everything. Purchasing and having your homelift installed is far less complicated than you might think. We will survey your home and provide you with a written quotation. After your decision to proceed, we will first carry out all the necessary work. The installation itself takes less than two days.



MAKING LIFE EASY

Freedom & choice, all in one lift.

Whether traveling standing, seated in a wheelchair or together with a carer, the Harmony FE Homelift will allow you to move freely between floors safely, smoothly and quietly. The lift features a wide range of cabin sizes to choose from so you are sure to find a model that fits your needs.

Our Harmony FE Homelift requires much less space than a conventional lift. There is no shaft or structure required and the footprint of the lift is so compact that it can be placed almost anywhere in your home.

COMFORTABLE AND EASY TO USE

Why the Harmony FE makes life easy



1

Easy-to-use wireless controls come as standard inside the cabin and at each floor level.



2

A simple push of the button controls the lift, positioned to suit your needs.



3

The aperture floor panel is automatically lifted or lowered by the carriage.



4

The guides can be positioned close to the wall to minimise impact on the room.



5

Low cabin floor construction ensures easy wheelchair access and egress.



6

The lift can be sent to the floor which is unoccupied, leaving a feeling of space in the room.

FEATURES

- Λ Reliable hydraulic drive system
- Λ Gloss white powder coated exterior and interior finish
- Λ Automatic motorised door
- Λ Low cabin floor profile for easy wheelchair access
- Λ Door open button on the external side of the lift cabin
- Λ Easy to use, one-touch wireless controls, with no need for constant pressure
- Λ Cabin controls are adjustable and landing controls wall mounted
- Λ Full height glazed door
- Λ Toughened scratch resistant glass panels
- Λ Light grey carpet covered interior panels
- Λ Charcoal carpeted floor
- Λ Four dimmable interior LED lights
- Λ Telephone (dependant on land line connection)
- Λ Integrated wireless smoke/heat detectors
- Λ Multiple emergency lowering systems
- Λ 325 kg (51 stone) weight capacity
- Λ 1 year parts and labour warranty
- Λ Designed and manufactured in Britain

OPTIONAL EXTRAS

- Λ Upholstered fold up seat
- Λ Joystick cabin control
- Λ Hand-held remote control
- Λ Radio isolation fob
- Λ Handrail
- Λ Grab points
- Λ Mirror
- Λ LED cabin side lighting
- Λ Extended warranties including service visits

OPTIONAL FINISHES

- Λ Choice of carpet colour
- Λ Cabin available in alternative RAL colours



CABIN DETAILS

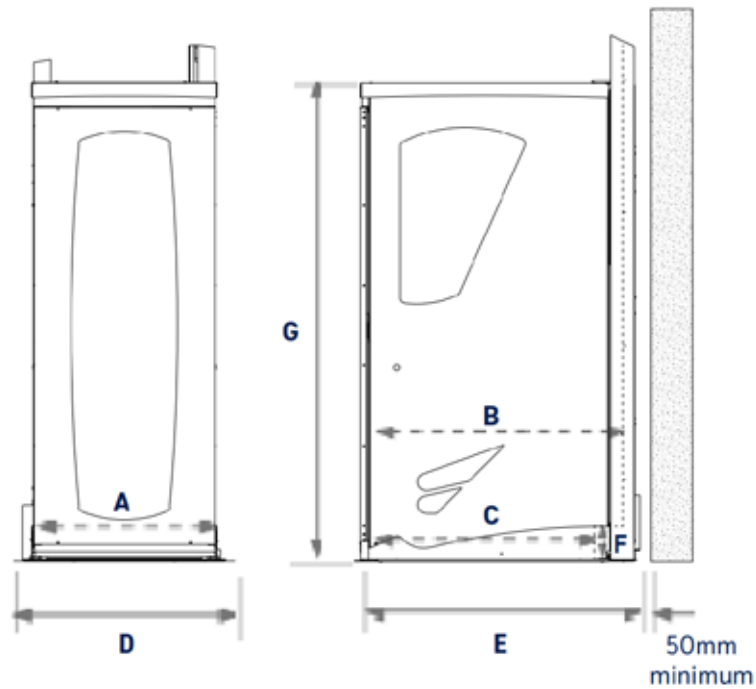

Lift Model	A Internal Width	B Internal Width Above Axle Cover	C Internal Length To Axle Cover	D External Width	E External Length	F Axle Cover Height	G Cabin Height	Travel	Capacity
Harmony FE C (Compact)	745	826	726	910	914	90	2160	2400-3600	325kg
Harmony FE S (Standard Wheelchair)	745	1148	1045	910	1235	90	2160	2400-3600	325kg
Harmony FE L (Wheelchair +Attendant)	745	1348	1245	910	1435	90	2160	2400-3600	325kg
Harmony FE LW (Wheelchair +Attendant)	880	1348	1245	1045	1435	90	2160	2400-3600	325kg

All Dimensions in MM

PEACE OF MIND

At Innovate Lifts , the Harmony FE lift is a premium product of exceptional quality that merges luxury with cutting-edge technology.

The safety of you and your family is our priority. This is why the Harmony FE Homelift is equipped with all the latest safety features as standard.

Fire safety is an important consideration. The Harmony FE Homelift maintains fire and smoke protection between the floors, whether it is parked upstairs or downstairs. Smoke or heat alarms ensure the lift performs correctly in case of activation.

- ^ We have options for extended warranty
- ^ Your lift comes with a 12 months parts and labour warranty, as standard.
- ^ All our lifts are lifetime tested to ensure reliability



INNOVATES PROMISE

SAFETY FIRST

Your safety is our primary concern. It is important that you feel safe and secure when you are using your Harmony FE Lift.

- ^ Pressure sensitive surfaces and safe edges
- ^ Emergency lowering in case of power cuts and easy to use manual lowering
- ^ 30-minute fire protection between the upper and lower floors, whether the lift is parked upstairs or downstairs, to the requirements of BS5900: 2012
- ^ Smoke or heat alarms provided on both floors

ENSURING WE COMPLY:

- ^ Compliant with the Machinery Directive
- ^ Independently certificated by a Notified Body as is our legal requirement
- ^ Compliant with British Standard BS 5900:2012
- ^ The Harmony Homelift fully complies with the Chartered Institute of Building Services Engineers (CIBSE) Guide D recommendations
- ^ Building and electrical work undertaken, complies to the relevant regulations.

FREQUENTLY ASKED QUESTIONS

IS IT POSSIBLE FOR THE LIFT TO STOP BETWEEN FLOORS WHEN I AM ON MY OWN?

If there is a power cut at your property, then the battery backup will maintain operational control of the lift to lower to the ground floor. If all else fails, the manual lowering system can be operated with assistance from outside the lift to enable you to travel to the ground floor. In addition, we provide a telephone inside the lift which is Included with your lift package. The telephone will require a connection to your incoming telephone landline.

CAN I USE MY WHEELCHAIR IN A HARMONY FE?

Yes you can. We offer three wheelchair models, the standard, the longer and the longer/wider. We have models which can accommodate a wheelchair, someone standing or a combination of both. Our Sales consultant can assist to decide on which size is most suitable.

DO INNOVATE LIFTS MANAGE THE BUILDING WORK?

Yes, we can complete all building work or alternatively, we can provide a Specification Guide to your builder. The choice is yours. Normally, no major structural work is required.

HOW MUCH SPACE DOES A HARMONY FE LIFT REQUIRE?

The four Harmony FE models are designed to minimise the external footprint and maximise the internal car space for every need. The Compact is the smallest. Please refer to the dimension guide on page 5.

WILL THE HARMONY FE AFFECT THE FIRE INTEGRITY OF MY HOME?

The Harmony FE lift is fire and smoke test certificated by an approved and accredited test laboratory and complies with BS5900:2012 in relation to through floor lifts. This covers fire safety for the Harmony FE Lift in both the lower and upper position.

I PLAN TO KEEP MY LIFT FOR A VERY LONG TIME, WILL INNOVATE LIFTS SERVICE AND CARE FOR MY LIFT?

Yes. We can provide a service and maintenance package to suit your requirements. Please contact our aftercare service team to discuss options that are available.

CAN INSTALLING A HARMONY FE LIFT BE CHEAPER THAN MOVING HOME?

Yes, almost certainly. We are often told by our clients that it was cheaper and less stressful than moving home.



HAMPSHIRE

Unit B, 34 Parham Drive
Woodside Trade Centre
Eastleigh
SO50 4NU

KENT

50A St Johns Road
Tunbridge Wells
Kent
TN4 9NY

T: 01892 557530

T: 02382 516739

E: info@innovatelifts.com

W: www.innovatelifts.com



innovate
lifts