



innovate
lifts

Lifestyle

Homelift

Call 01892 557530 for free and impartial advice



Why choose Innovate Lifts?

Steve Marriner founded Innovate Lifts in 2016 after 40 years of industry experience, to bring new life to the lift industry and push its boundaries.

Compliance with safety standards is a top priority for Innovate Lifts. Our skilled team of experts adds a touch of creativity and uniqueness to every Lifestyle Homelift ensuring it is tailored to your specific needs. We are committed to providing a personalized and friendly service that exceeds your expectations, and we look forward to bringing innovation and inspiration to your home.

We understand that every customer is different, and we take pride in our ability to listen carefully to your needs and provide compassionate, empathetic solutions that address your concerns effectively. At Innovate Lifts, we are dedicated to supporting you through life's challenges, and we are honored to be a part of your journey.

We will take care of everything

Purchasing and having your homelift installed is far less complicated than you might think.

We will survey your home and provide you with a written quotation. After your decision to proceed, we will first carry out all the necessary work. The installation itself takes less than two days.

Making life easy

Stylish

The stylish Lifestyle Homelift has been designed by our manufactures team to make your life easier.

Created specially for the home, it is elegant and compact and will fit neatly into rooms of all sizes, practically anywhere you choose. It can even be custom made to suit your décor.

The Lifestyle Homelift will future proof your home so you don't have to worry about the emotional stress and upheaval of moving house if the stairs become too much.



Key benefits

- Safe and reliable hydraulic drive system
- A low cabin floor profile, less than two inches, makes it easy to step into the lift
- One-touch controls. No need for constant pressure to the controls
- Fire and Smoke Protection as standard to ensure fire safety
- Safety glass vision panels which will not scratch or discolour
- Wireless landing controls making it easy to decide on wall control location
- Smart corner design minimises the lift footprint
- No lift shaft required minimises the space required for the lift
- Quick, no mess, no fuss installation
- Designed and manufactured in Britain



Quality comes as standard

Tasteful and elegant, enjoy these premium features with your Lifestyle Homelift.

To ensure the quality and reliability of every lift, we assemble all component parts. Door locks, printed circuit boards, hydraulic pumps and rams are rigorously tested in-house before they leave the factory.

The lift uses Terry Group designed bespoke electronic control systems.

Each lift is fully tested when the installation is complete, following which, a test certificate is issued which supports the warranty.



As standard, the lift is fitted with laminated safety glass which is scratch resistant and far stronger than cheaper alternatives



Controllable dimmed ceiling down lighting

Straight stainless steel handrail



Fire seals for both levels

Easy to use lift controls



Wireless landing controls



Neatly tucked away to maximise your living space, the lift guides are close the walls at each level to give you un-obstructed floor space.

Make it your own

Optional features



Fold up seat complete with rail opposite

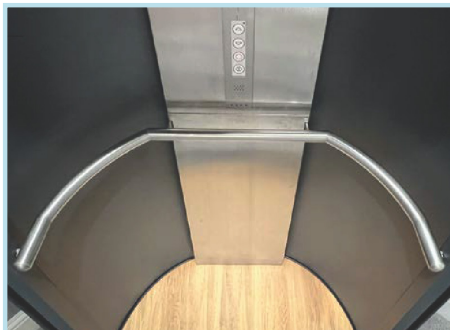

Full curve rail to rear

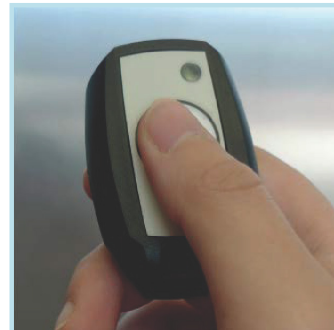

Hand held isolation fob

Your Lifestyle Homelift can be tailored to suit your tastes and your home.
Choose from our range of colours and finishes to create the perfect lift for you.

Colour options

Centre console: Painted



silver*
RAL 7047



gainsborough
RAL 9007

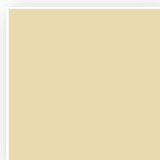

sandstone
RAL 1015

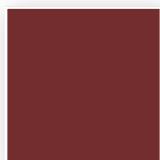

claret
RAL
3004

Centre console: Upholstered



silver grey*

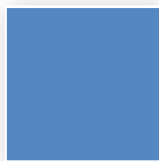

lupin



sandstone



rosso (leather)

Flooring

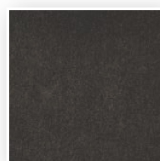

charcoal
carpet*

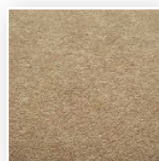

biscuit
carpet



mocha
carpet

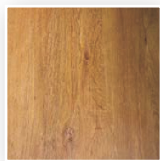

light oak
laminat



Lifestyle Homelift
available in alternative
colour

* These options are standard



Peace of mind

At Innovate Lifts , the Lifestyle lift is a premium product of exceptional quality that merges luxury with cutting-edge technology.

The safety of you and your family is our priority. This is why the Lifestyle Lift is equipped with all the latest safety features as standard.

Fire safety is an important consideration. The Lifestyle Lift maintains fire and smoke protection between the floors, whether it is parked upstairs or downstairs. Smoke or heat alarms ensure the lift performs correctly in case of activation.

- We have options for extended warranty
- Your lift comes with a 12 months parts and labour warranty, as standard.
- All our lifts are lifetime tested to ensure reliability

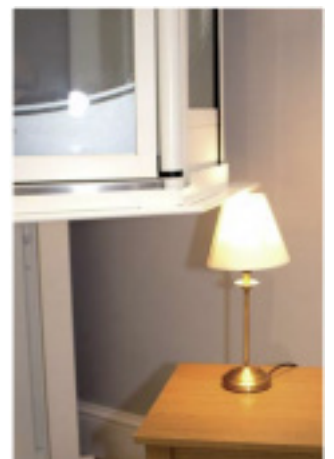

Pressure sensitive safety surfaces stop the lift if obstructed from above or below

Key dimensions

Slim and Stylish, the Lifestyle Lift has a small footprint and will fit discreetly almost anywhere in your home.

Positioned against the wall

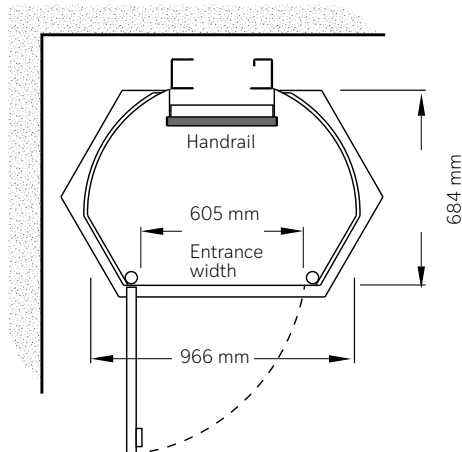

Positioned in the corner

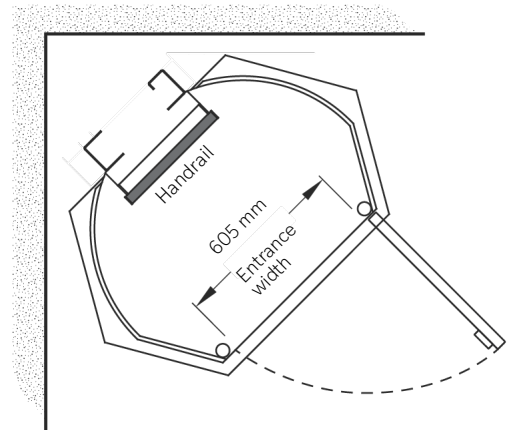

Additional dimensions available on request.

■ Internal ceiling height: 1985mm

■ Internal car width: 854mm

■ Internal car depth: 597mm

■ Maximum travel: 3.6m

■ Minimum ceiling height to the upper level: 2250mm

Frequently asked questions

Is it possible for the lift to stop between floors when I am on my own?

If there is a power cut at your property, then the battery backup will maintain operational control of the lift to lower to the ground floor. If all else fails, the manual lowering system can be operated with assistance from outside the lift to enable you to travel to the ground floor. In addition, we provide a telephone inside the lift which is included with your lift package. The telephone will require a connection to your incoming telephone landline.

Can I use my wheelchair in a Lifestyle Homelift?

No, however, we have designed the Harmony and Harmony FE lifts in collaboration with our customers to meet the requirements of a wheelchair user or an attended wheelchair user. Illustrated on the back of this brochure.

Do Innovate Lifts manage the building work? Yes, we can complete all building work or alternatively, we can provide a Specification Guide to your builder. The choice is yours. Normally, no major structural work is required.

How much space does a Lifestyle Homelift require?

The footprint of the Lifestyle Homelift is smaller than that of a typical armchair. Please refer to size diagram above or we can provide a footprint template to position in your home.

Is the Lifestyle Homelift safe in the event of a fire?

The Lifestyle Homelift is fire and smoke test certificated by an approved and accredited test laboratory and complies with BS5900:2012 in relation to through floor lifts. This covers fire safety for the Lifestyle Homelift in both the lower and upper position.

I plan to keep my lift for a very long time, will Innovate Lifts service and care for my lift?

Yes. We can provide a service and maintenance package to suit your requirements. Please contact our aftercare service team to discuss options that are available.

Can installing a Lifestyle Homelift be cheaper than moving home?

Yes, almost certainly. We are often told by our customers that it was cheaper and less stressful than moving home.



For further information or to book your free no obligation consultation, call us today on **01892 557530** or visit **www.innovatelifts.com** to view our full range of homelifts



Harmony Wheelchair Homelift



Harmony Fully Enclosed Homelift

innovate
lifts

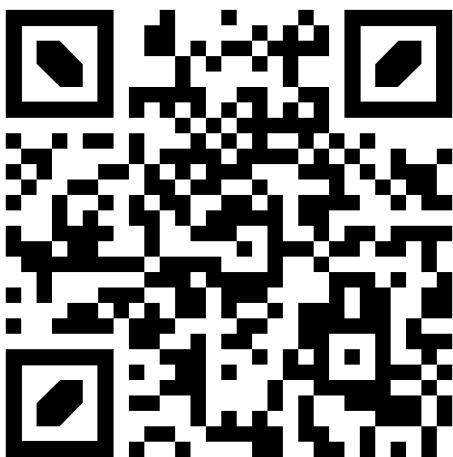

Innovate Lifts Ltd
Office 1, The Lakeside Centre,
Eastleigh, Hampshire SO50 5PE

Tel: 01892 557530

Tel: 02382 516739

www.innovatelifts.com

info@innovatelifts.com